

Sweet Dreams

{ FEATURING SUGAR COLLECTION }

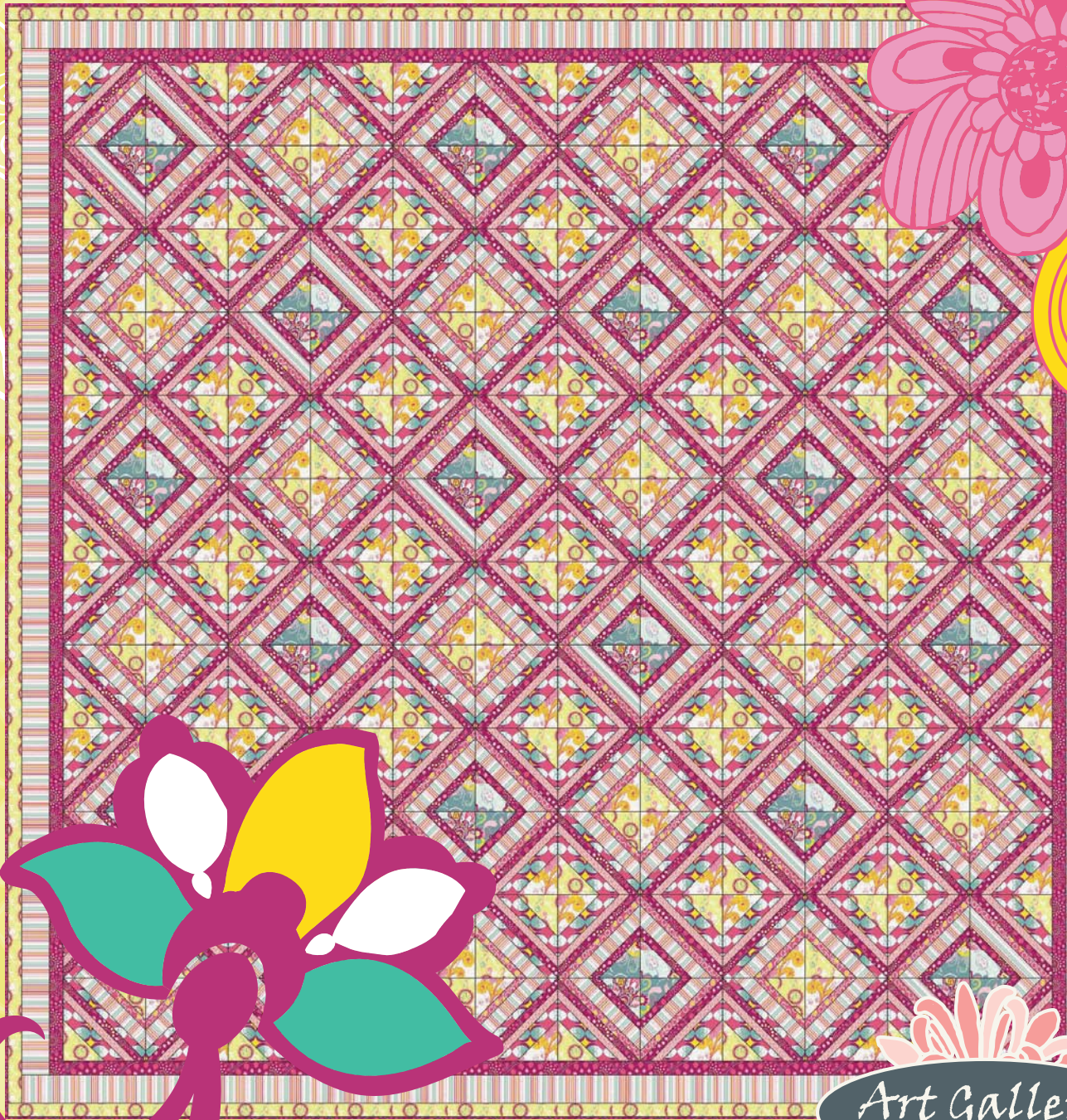

Art Gallery
FABRICS

FREE PROJECT SHEET
DESIGNED WITH LOVE BY Pat Bravo

QUILT DESIGNED
WITH LOVE BY Pat Bravo

Sweet Dreams

FINISHED SIZE: 80" by 80"
BLOCK SIZE: 6" by 6"

To download the instructions for this pattern visit

www.artgalleryfabrics.com

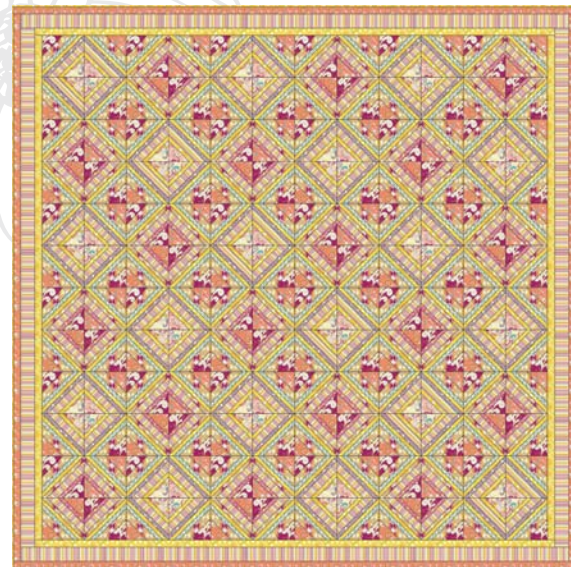

SUGAR

FRUITY SHERBET



SU-908
Cool Whipped Florets



SU-907
Juicy Scents



SU-906
White Swirled Trees



SU-905
Dazzling Wheels



SU-904
Lime Fizzy Bubbles



SU-903
Fruity Scoops

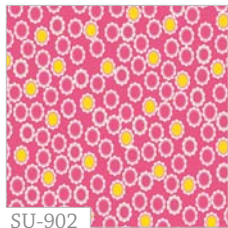

SU-902
Pink Lacy Charms



SU-901
Bubblegum Ribbons



SU-900
Sugared Heart Chains

KIT QUANTITY

SU-906	3/4 yd.	SU-903	1 7/8 yd.
SU-900	1 1/8 yd.	SU-905	2 yd.
SU-904	1 1/8 yd.	SU-902	7/8 yd.
SU-901	2 1/4 yd.	SU-907	1/4 yd.
SU-908	1/4 yd.	Backing	5 1/2 yd.

CREAMY GELATO

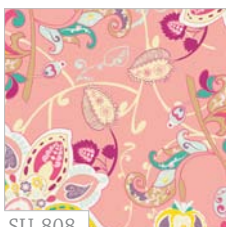

SU-808
Warm Whipped Florets

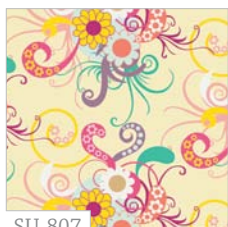

SU-807
Creamy Scents



SU-806
Fuchsia Swirled Trees



SU-805
Flashy Wheels



SU-804
Apricot Fizzy Bubbles

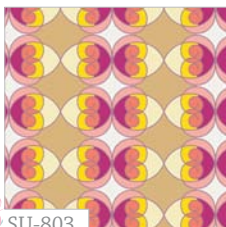

SU-803
Caramel Scoops



SU-802
Violet Lacy Charms

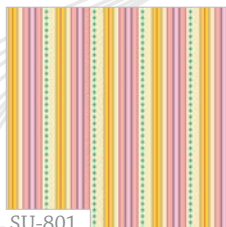

SU-801
Honey Ribbons



SU-800
Glazed Heart Chains

COLOR OPTION KIT QUANTITY

SU-806	3/4 yd.	SU-803	1 7/8 yd.
SU-800	1 1/8 yd.	SU-805	2 yd.
SU-804	1 1/8 yd.	SU-802	7/8 yd.
SU-801	2 1/4 yd.	SU-807	1/4 yd.
SU-808	1/4 yd.	Backing	5 1/2 yd.



Sweet Dreams

Finished Size: 80" by 80"
Block Size: 12" by 12"

SUGAR COLLECTION

FABRICS DESIGNED BY PATRICIA BRAVO
QUILT CONSTRUCTED BY PRISCILLA FOR
ART GALLERY FABRICS



FABRIC REQUIREMENTS

Fabric A	SU-906	3/4 yd.
Fabric B	SU-900	1 1/8 yd.
Fabric C	SU-904	1 1/8 yd.
Fabric D	SU-901	2 1/4 yd.
Fabric E	SU-908	1/4 yd.
Fabric F	SU-903	1 7/8 yd.
Fabric G	SU-905	2 yd.
Fabric H	SU-902	7/8 yd.
Fabric I	SU-907	1/4 yd.

Backing SU-903 5 1/2 yd. (suggested)
Binding fabric included SU-905 (FABRIC G)

CUTTING DIRECTIONS

This quilt was made from blocks composed of four units of strips cut in 45° angle and set forming diamonds. It was made in two color combinations. (1/4" seam allowances are included).

FOR BLOCK COMBINATION 1, CUT (18 blocks total)

- Eighteen (18) 4 1/4" squares from fabric **A**, cut them once diagonally to get 36 triangles.
- Eighteen (18) 4 1/4" squares from fabric **I**, cut them once diagonally to get 36 triangles.
- Eighteen (18) 4 1/4" squares from fabric **C**, cut them once diagonally to get 36 triangles.
- Eighteen (18) 4 1/4" squares from fabric **E**, cut them once diagonally to get 36 triangles.
- Seventy-two 8 1/2" by 1 1/2" strips from fabric **F**
- Seventy-two 9 1/2" by 1" strips from fabric **B**
- Seventy-two 10 3/4" by 1" strips from fabric **G**
- Seventy-two 10 3/4" by 1" strips from fabric **H**
- Seventy-two 9 1/2" by 1 1/2" strips from fabric **D**
- Seventy-two 7 1/2" by 1" strips from fabric **G**

FOR BLOCKS COMBINATION 2, CUT (18 blocks total)

- Thirty-six (36) 4 1/4" squares from fabric **A**, cut them once diagonally to get 72 triangles.
- Thirty-six (36) 4 1/4" squares from fabric **C**, cut them once diagonally to get 72 triangles.
- Seventy-two 8 1/2" by 1 1/2" strips from fabric **F**
- Seventy-two 9 1/2" by 1" strips from fabric **B**
- Seventy-two 10 3/4" by 1" strips from fabric **G**
- Seventy-two 10 3/4" by 1" strips from fabric **F**
- Seventy-two 9 1/2" by 1 1/2" strips from fabric **D**
- Seventy-two 7 1/2" by 1" strips from fabric **H**

IMPORTANT HINT FOR FABRIC PLACEMENT:

All the letters shown in color pink represent the pieces or patches but ALSO represent the fabric styles explained in "FABRIC REQUIREMENTS" (notice they are also represented in the same color).

FOR BORDERS CUT

For Inner Border

Two (2) 72 1/2" by 1 1/2" strips from fabric **G***
Two (2) 74 1/2" by 1 1/2" strips from fabric **G***

For Middle Border

Two (2) 74 1/2" by 2 1/2" strips from fabric **D***
Two (2) 78 1/2" by 2 1/2" strips from fabric **D***

For Outer Border

Two (2) 78 1/2" by 1 1/2" strips from fabric **C***
Two (2) 80 1/2" by 1 1/2" strips from fabric **C***

* (in order to get these long strips you need to join two Width Of Fabric strips together)

BLOCK CONSTRUCTION

(sew fabrics right sides together and with a 1/4" seam allowance)

All 36 blocks are constructed the same way

FOR BLOCK COMBINATION 1 (18 blocks total)

(This block is made from 4 units of strips set in a 45° angle, shown in DIAGRAM 1)

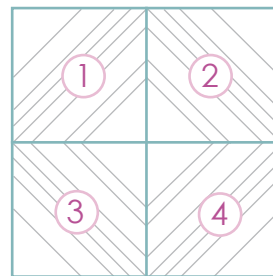

DIAGRAM 1
4 units of the block

- For units **1** and **4**, fold one strip each from fabrics **F-B-G-H-D-G** and one triangle each from fabrics **F-I** in half and press with an iron to mark a crease to all of them. DIAGRAM 2

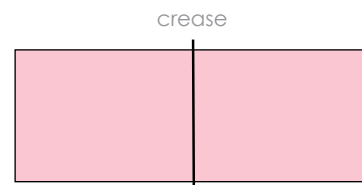
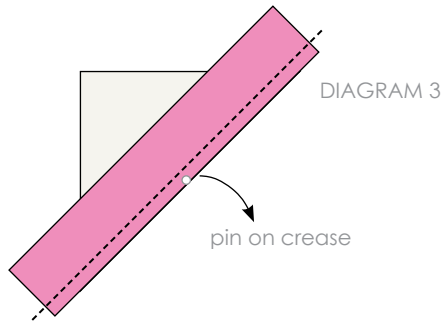
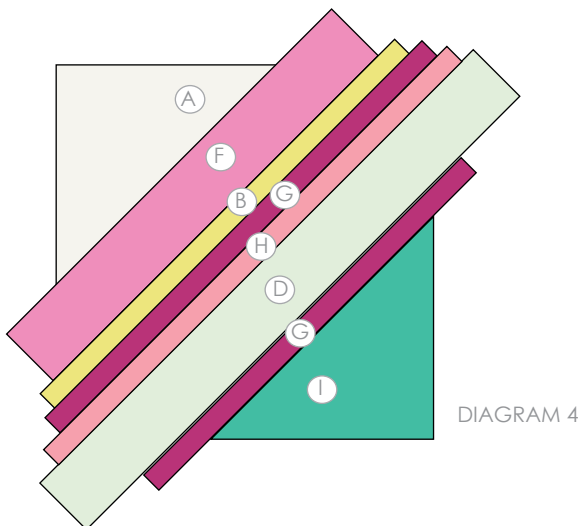

DIAGRAM 2

- Position one fabric **F** strip over one fabric **A** triangle. Pin where the creases match. Sew on the entire edge (DIAGRAM 3). Open and press.



- Position one fabric **B** strip over one fabric **F** strip. Pin again where the creases match. Sew on the entire edge. Open and press. Keep adding fabric strips **G**, **H**, **D**, **G** in the same way (as shown below).



- Position one fabric **I** triangle over the last fabric **G** strip. Pin again where the creases match. Sew on the entire edge. Open and press. DIAGRAM 4

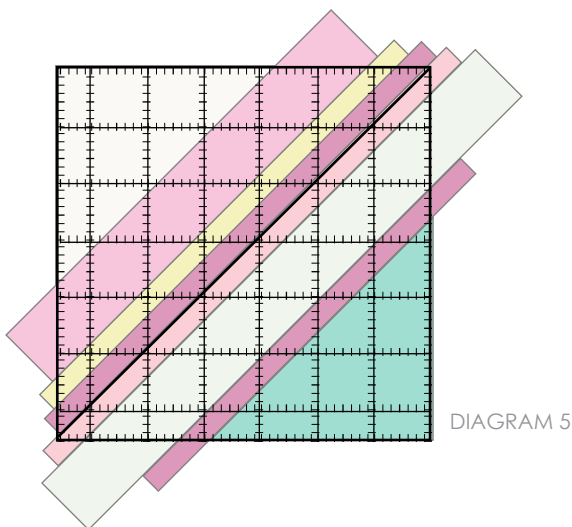

- Put a ruler over the unfinished unit, and center it, matching one seam with the 45° guide (provided in the ruler). Trim all four sides of the block to a 6 1/2" size. DIAGRAM 5

- For units **2** and **3**, follow the same steps, but replace corner triangles with fabrics **C-E** (DIAGRAM 6)

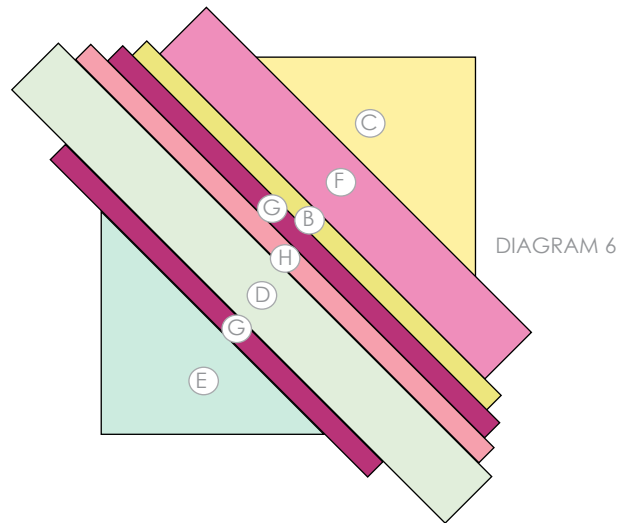

FABRIC COMBINATIONS LAYOUT FOR UNITS

- Make a total of 36 units **1** and **4**
- Make a total of 36 units **2** and **3**

FOR BLOCKS COMBINATION 2 (18 blocks total)

(This block is made from 4 units of strips set in a 45° angle, shown in DIAGRAM 7)

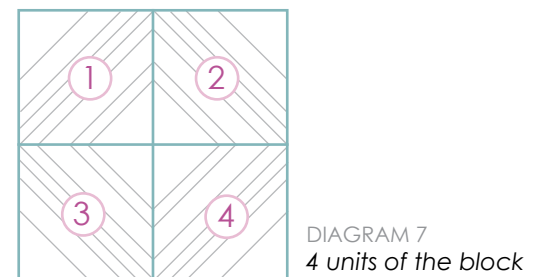

- For units **1** and **4**, fold one strip each from fabrics **F-B-G-F-D-H** and two triangles from fabric **A** in half and press with an iron to mark a crease to all of them. DIAGRAM 8



- Position one fabric **F** strip over one fabric **A** triangle. Pin where the creases match. Sew on the entire edge (DIAGRAM 9). Open and press.

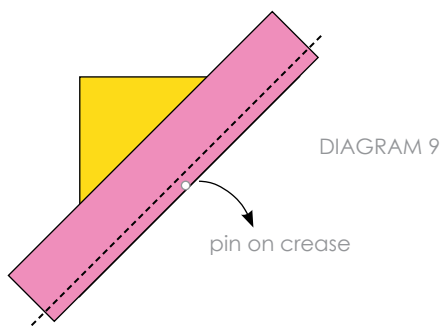

DIAGRAM 9

- Position one fabric **B** strip over one fabric **F** strip. Pin again where the creases match. Sew on the entire edge. Open and press. Keep adding fabric strips **G**, **F**, **D**, **H** in the same way. **DIAGRAM 10**

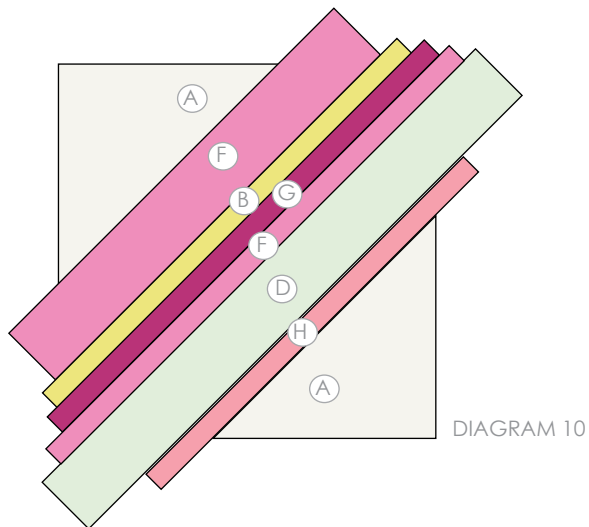

DIAGRAM 10

- Position one fabric **A** triangle over the last fabric **H** strip. Pin again where the creases match. Sew on the entire edge. Open and press. **DIAGRAM 10**
- Put a ruler over the unfinished unit, and center it, matching one seam with the 45° guide (provided in the ruler). Trim all four sides of the block to a 6 1/2" size. **DIAGRAM 11**

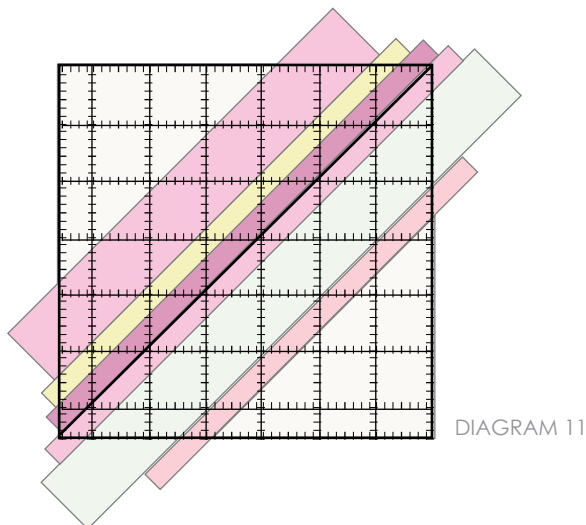

DIAGRAM 11

- For units **2** and **3**, follow the same steps, but replace corner triangles with fabric's **C**. **DIAGRAM 12**

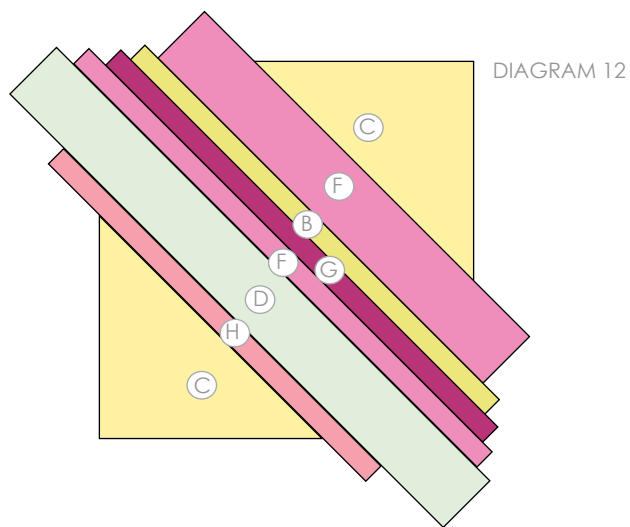

DIAGRAM 12

FABRIC COMBINATIONS LAYOUT FOR UNITS

- Make a total of 36 units **1** and **4**
- Make a total of 36 units **2** and **3**



UNITS ASSEMBLY

(sew all fabrics right sides together)

FOR BLOCKS COMBINATION 1 (18 blocks total)

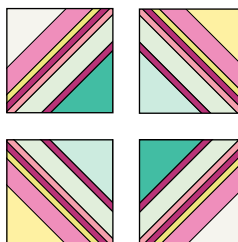

- To make block with combination 1, position one unit **2** on top of a unit **1** and match the intersections with pins. Sew along the edge with a 1/4" seam. Repeat the process with unit **4** on top of unit **3**. Open both units and press. Position the lower unit on top of the upper unit and locking intersections with pins, sew over the entire edge. Open and press. You now finished your Block Combination 1. Make a total of 18 Blocks.

FOR BLOCKS COMBINATION 2 (18 blocks total)

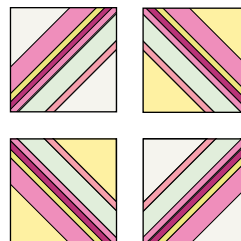

- To make block with combination 2, position one unit **2** on top of a unit **1** and match the intersections with pins. Sew along the edge with a 1/4" seam. Repeat the process with unit **4** on top of unit **3**. Open both units and press. Position the lower unit on top of the upper unit and locking intersections with pins, sew over the entire edge. Open and press. You now finished your Block Combination 2. Make a total of 18 Blocks.

QUILT TOP ASSEMBLY

(sew all seams right sides together)

- Start piecing the first row of six blocks alternating blocks 1 and 2, one block each (**Follow the front cover picture for block placement**). Press seams open.
- After you finish, sew the remaining rows being careful of opposing the combinations (**Follow the front cover picture for block placement**).
- After you finish, sew the rows together (**Follow the front cover picture for block placement**). Take much care to match block seam's intersections between each row (lock them with pins if necessary). Press all seams toward the same direction.
- Press the WHOLE TOP with a hot steam iron.

BORDERS ASSEMBLY

(sew right sides together)

For the inner border

- Sew two 72½" by 1 ½" fabric **G** strips along the opposite sides (left & right) of the top with a ¼" seam allowance. Press open.
- Sew the other two 74 ½" by 1 ½" fabric **G** strips along the top and bottom sides of the top with a ¼" seam allowance. Press open.

For the middle border

- Sew two 74½" by 2 ½" fabric **D** strips along the opposite sides (left & right) of the top with a ¼" seam allowance. Press open.
- Sew the other two 78 ½" by 2 ½" fabric **D** strips along the top and bottom sides of the top with a ¼" seam allowance. Press open.

For the outer border

- Sew two 78 ½" by 1 ½" fabric **C** strips along the opposite sides (left & right) of the top with a ¼" seam allowance. Press open.
- Sew the other two 80 ½" by 1 ½" fabric **C** strips along the top and bottom sides of the top with a ¼" seam allowance. Press open.

QUILT ASSEMBLY

(sew right sides together)

- Place BACKING FABRIC on a large surface **wrong** side up. Stretch it with masking tape against that surface.
- Place BATTING on top of backing fabric.
- Place TOP on top of the batting with **right** side facing up. Smooth away wrinkles using your hands.
- Pin all layers together and baste with basting thread, using long stitches. You can also use safety pins to join the layers.
- Machine or hand quilt starting at the center and working towards the corners. Remember that quilting motives are a matter of personal preference. Have fun choosing yours!
- After you finished, trim excess of any fabric or batting, squaring the quilt to proceed to bind it.

BINDING

(sew right sides together)

- Cut enough strips 1 ½" wide by the width of the fabric **G** to make a final strip 332" long. Start sewing the binding strip in the middle of one of the sides of the quilt, placing the strip right side down and leaving an approximated 5" tail. Sew with ¼" seam allowance (using straight stitch), aligning the strip's raw edge with the quilt top's raw edge.
- Stop stitching ¼" before the end of the quilt (DIAGRAM B1). Clip the threads. Remove the quilt from under the machine presser foot. Fold the strip in a motion of 45° and upward, pressing with your fingers (DIAGRAM B2). Hold this fold with your finger, bring the strip down in line with the next edge, making a horizontal fold that aligns with the top edge of the quilt (DIAGRAM B3). Start sewing at ¼" of the border, stitching all the layers. Do the same in the four corners of the quilt.
- Stop stitching before you reach the last 5 or 6 inches. Cut the threads and remove the quilt from under the machine presser foot. Lay the loose ends of the binding flat along the quilt edge, folding the ends back on themselves where they meet. Press them together to form a crease. Using this crease as the stitching line, sew the two open ends of the binding with right sides together (you can help yourself marking with a pencil if the crease is difficult to see).
- Trim seam to ¼" and press open. Complete the sewing. Turn binding to back of the quilt, turn raw edge inside and stitch by hand using blind stitch.

DIAGRAM B1

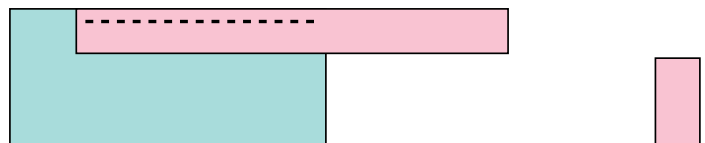

DIAGRAM B3

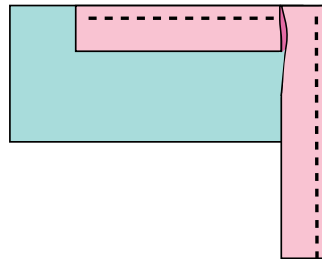
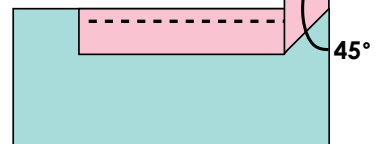

DIAGRAM B2



CONGRATULATIONS!

NOTES: While all possible care has been taken to ensure the accuracy of this pattern, we are not responsible for printing errors or the way in which individual work varies. Please read instructions carefully before starting the construction of this quilt. If desired, wash and iron your fabrics before starting to cut.